



MADE EASY

India's Best Institute for IES, GATE & PSUs

Delhi | Bhopal | Hyderabad | Jaipur | Pune | Kolkata

Web: www.madeeasy.in | E-mail: info@madeeasy.in | Ph: 011-45124612

FLUID MECHANICS

CIVIL ENGINEERING

Date of Test : 27/02/2025

ANSWER KEY >

- | | | | | |
|--------|---------|---------|---------|---------|
| 1. (a) | 7. (a) | 13. (b) | 19. (d) | 25. (b) |
| 2. (a) | 8. (c) | 14. (d) | 20. (b) | 26. (a) |
| 3. (d) | 9. (c) | 15. (c) | 21. (d) | 27. (c) |
| 4. (b) | 10. (b) | 16. (b) | 22. (c) | 28. (a) |
| 5. (c) | 11. (c) | 17. (c) | 23. (d) | 29. (d) |
| 6. (c) | 12. (a) | 18. (b) | 24. (b) | 30. (c) |

DETAILED EXPLANATIONS

1. (a)

$$\psi = 2xy$$

$$\therefore u = \frac{\partial \psi}{\partial y} = 2x$$

$$v = -\frac{\partial \psi}{\partial x} = -2y$$

At (2, -2), $u = 4$, $v = 4$

$$\therefore |\vec{V}| = \sqrt{u^2 + v^2} = 4\sqrt{2}$$

2. (a)

$$\therefore V = \sqrt{2gh \left(\frac{S_m}{S} - 1 \right)}$$

where,

h = Manometric deflection

S_m = Specific gravity of manometric fluid

S = Specific gravity of flowing fluid

$$\therefore 1.2 = \sqrt{2 \times 9.81 \times h \left(\frac{1.4}{1} - 1 \right)}$$

$$\Rightarrow h = \frac{(1.2)^2}{2 \times 9.81 \times 0.4} = 0.1835 \text{ m} = 18.35 \text{ cm}$$

3. (d)

$$\text{Centre of pressure, } h^* = \frac{I_G}{Ah} + \bar{h} \quad \rightarrow \quad \text{For vertical surface}$$

$$h^* = \frac{I_G \sin^2 \theta}{Ah} + \bar{h} \quad \rightarrow \quad \text{For inclined surface}$$

For any plane surface $\left(\frac{I_G}{Ah} \right)$ is always positive

So, h^* is always below the centroid of area.

4. (b)

$$\tau = \frac{\partial P}{\partial x} \times \frac{R}{2} = \frac{70 \times 1000}{30} \times \frac{0.3}{2} = 350 \text{ Pa}$$

5. (c)

Boundary layer thickness (δ):

It is defined as the distance from the boundary surface in which the velocity reaches the 99% of the velocity of the main stream.

$$\text{At } y = \delta, \quad V = 0.99 V_o$$

V_o = Free stream velocity

6. (c)

The divergence of the velocity field is

$$\begin{aligned}\text{div. } V = \nabla \cdot V &= \frac{\partial}{\partial x}(3t) + \frac{\partial}{\partial y}(xz) + \frac{\partial}{\partial z}(ty^2) \\ &= 0 + 0 + 0 = 0\end{aligned}$$

Therefore the velocity field is incompressible.

The curl of this velocity field is

$$\begin{aligned}\text{curl. } V = \nabla \times V &= \begin{vmatrix} \hat{i} & \hat{j} & \hat{k} \\ \frac{\partial}{\partial x} & \frac{\partial}{\partial y} & \frac{\partial}{\partial z} \\ 3t & xz & ty^2 \end{vmatrix} \\ &= (2ty - x)\hat{i} + z\hat{k} \neq 0\end{aligned}$$

Therefore the flow field is rotational.

7. (a)

A sharp crested weir is more susceptible to submergence than a broad crested weir.

8. (c)

In laminar flow friction factor depends only on Reynold's number but in case of turbulent flow, the friction factor will depend upon Reynold's number and friction both.

9. (c)

Examples of a forced vortex:

- (i) A vertical cylinder containing liquid which is rotated about its centre axis with a constant angular velocity.
- (ii) Flow of liquid inside the impeller of a centrifugal pump.
- (iii) Flow of water through the runner of a turbine.

Examples of the free vortex:

- (i) Flow of liquid through a hole provided at the bottom of a container.
- (ii) Flow of liquid around a circular bend in a pipe.
- (iii) A whirlpool in a river.
- (iv) Flow of fluid in a centrifugal pump casing.

10. (b)

Let V be the volume of fluid

$$\therefore dV = \frac{-6}{100} \times V$$

$$\Rightarrow \frac{-dV}{V} = 0.06$$

$$\begin{aligned}\therefore \text{Increase in pressure } \Delta P &= \frac{-\Delta V}{V} \times K \\ &= 1.5 \times 10^9 \times 0.06 \text{ Pa} \\ &= 0.090 \text{ GPa}\end{aligned}$$

11. (c)

$$\begin{aligned} \text{Power at the base of nozzle} &= mgH \\ &= \rho QgH \\ &= 10^3 (0.18) (9.81) (32) \text{ W} = 56.51 \text{ kW} \end{aligned}$$

$$V_1 = \frac{Q}{a} = \frac{0.18}{7500 \times 10^{-6}} = 24 \text{ m/s}$$

$$\begin{aligned} \text{Power at the exit of nozzle} &= \frac{1}{2} m V_1^2 = \frac{1}{2} \rho Q V_1^2 \\ &= \frac{1}{2} \times 10^3 (0.18) (24)^2 = 51.84 \text{ kW} \end{aligned}$$

$$\begin{aligned} \text{Power lost in the nozzle} &= 56.51 - 51.84 \\ &= 4.67 \simeq 4.7 \text{ kW} \end{aligned}$$

12. (a)

$$\begin{aligned} \text{Discharge ratio, } Q_r &= \frac{Q_m}{Q_p} = L_{r_h} (L_{r_v})^{3/2} \\ &= \frac{1}{625} \times \left(\frac{1}{36}\right)^{3/2} = \frac{1}{135000} \end{aligned}$$

$$\begin{aligned} \therefore Q_p &= \frac{Q_m}{Q_r} = 0.025 \times 135000 \\ &= 3375 \text{ m}^3/\text{s} \end{aligned}$$

13. (b)

$$\begin{aligned} \text{For rough pipe, } \frac{1}{\sqrt{f}} &= 2 \log_{10} \left(\frac{R}{k_s} \right) + 1.74 \\ &= 2 \log_{10} \left(\frac{0.30}{0.20 \times 10^{-3}} \right) + 1.74 = 8.09 \\ f &= 0.015 \\ \tau_{\text{wall}} &= \rho \frac{f V^2}{8} \end{aligned}$$

$$\text{where, } V = V_{\text{avg}} = \frac{Q}{A} = \frac{0.64}{\frac{\pi}{4} \times 0.6^2} = 2.264 \text{ m/s}$$

$$\therefore \tau_{\text{wall}} = \frac{1000 \times 0.015 \times 2.264^2}{8} = 9.61 \text{ N/m}^2$$

14. (d)

Since air column weight is negligible, equating pressures on both sides of dotted line, one gets

$$\begin{aligned} p_A &= p_B + (0.020 \times 0.8 \times 9.81) \sin 30^\circ \\ \Rightarrow p_A - p_B &= 0.07848 \text{ kN/m}^2 \\ &= 78.48 \text{ N/m}^2 \simeq 78.5 \text{ N/m}^2 \end{aligned}$$

15. (c)

$$H \propto \frac{Q^2}{D^5} \quad (\text{Since } H \text{ is constant})$$

$$\therefore Q^2 \propto D^5$$

$$\left(\frac{Q_1}{Q_2}\right)^2 = \left(\frac{D_1}{D_2}\right)^5$$

$$(\because Q_2 = 2Q_1)$$

$$\left(\frac{Q_1}{2Q_1}\right)^2 = \left(\frac{D_1}{D_2}\right)^5$$

$$0.7578 = \frac{D_1}{D_2}$$

$$\frac{D_2}{D_1} = 1.3195$$

$$\frac{A_2}{A_1} = \frac{\frac{\pi}{4} \times D_2^2}{\frac{\pi}{4} D_1^2} = (1.3195)^2 = 1.7411$$

$$\therefore A_2 = 1.7411A_1$$

\therefore Increase in cross-sectional area

$$= \frac{A_2 - A_1}{A_1} \times 100$$

$$= \frac{1.7411A_1 - A_1}{A_1} \times 100 = 74.11\%$$

16. (b)

For laminar flow through circular pipe,

$$u = -\frac{1}{4\mu} \frac{\partial P}{\partial x} (R^2 - r^2)$$

$$\Rightarrow 0.75 = -\frac{1}{4\mu} \frac{\partial P}{\partial x} (10^2 - 5^2) \quad \dots(i)$$

$$\text{Also, } u_{\max} = -\frac{1}{4\mu} \frac{\partial P}{\partial x} (10^2 - 0^2) \quad \dots(ii)$$

$$\frac{0.75}{u_{\max}} = \frac{10^2 - 5^2}{10^2}$$

$$\Rightarrow u_{\max} = 1.0 \text{ m/s}$$

17. (c)

$$v^* = \sqrt{\frac{\tau_0}{\rho}} = \sqrt{\frac{800}{1000}} = 0.894 \text{ m/s}$$

$$\delta' = \frac{11.6\nu}{v^*} = \frac{11.6 \times 10^{-6}}{0.894} = 12.975 \times 10^{-6} \text{ m}$$

$$\therefore \frac{k_s}{\delta'} = \frac{0.12 \times 10^{-3}}{12.975 \times 10^{-6}} = 9.25$$

18. (b)

$$\begin{aligned} \text{Total head} &= \frac{p}{\rho g} + \frac{\alpha v^2}{2g} + z \\ \text{Pressure head} &= -2 \text{ cm of mercury} \\ &= \frac{-2 \times 13.6}{0.75} \text{ cm of oil} \\ &= -0.363 \text{ m of oil} \\ \text{Velocity, } v &= \frac{Q}{A} = \frac{0.07}{\frac{\pi}{4} \times 0.15^2} = 3.96 \text{ m/s} \\ \text{Velocity head} &= \frac{\alpha v^2}{2g} = \frac{1.1 \times 3.96^2}{2 \times 9.81} = 0.879 \text{ m} \\ \text{Datum head, } z &= 12 \text{ cm} = 0.12 \text{ m} \\ \text{Total head} &= -0.363 + 0.879 + 0.12 \\ &= 0.636 \text{ m} \end{aligned}$$

19. (d)

Depth of water at bottom of tank = $3 + 0.6 = 3.6 \text{ m}$

Area at the bottom of tank = $4 \times 2 = 8 \text{ m}^2$

Total pressure force at the bottom,

$$F = \rho g Ah$$

Weight of water in tank, $W = \rho g \times \text{Volume}$

\therefore Ratio,

$$\begin{aligned} \frac{F}{W} &= \frac{\rho g Ah}{\rho g V} = \frac{Ah}{V} \\ &= \frac{8 \times 3.6}{(3 \times 0.4 \times 2 + 4 \times 0.6 \times 2)} = 4 \end{aligned}$$

20. (b)

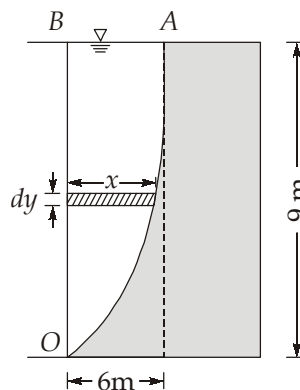

Equation of curve OA is $y = y_0 \left(\frac{x}{x_0} \right)^2 = 9 \left(\frac{x}{6} \right)^2 = \frac{x^2}{4}$

$\therefore x = \sqrt{4y}$

$$x = 2\sqrt{y}$$

Length of dam = 6 m

Vertical thrust exerted by water,

$$\begin{aligned}
 F_v &= \rho g V && \text{(Weight of water in portion } ABO) \\
 &= \rho g \times \text{Area of } OAB \times \text{Length of dam} \\
 &= 1010 \times 9.81 \times \left[\int_0^9 x \times dy \right] \times 6 \\
 &= 1010 \times 9.81 \left[\int_0^9 2\sqrt{y} dy \right] \times 6 \\
 &= 1010 \times 9.81 \times 2 \times \frac{2}{3} \times 9^{3/2} \times 6 = 2140149.6 \text{ N}
 \end{aligned}$$

$$\therefore F_v = 2140.15 \text{ kN}$$

21. (d)

Given, $u = 2y^2$, $v = 3x$, $w = 0$

Convective acceleration is given by,

$$\vec{a} = a_x \hat{i} + a_y \hat{j} + a_z \hat{k}$$

where,

$$\begin{aligned}
 a_x &= \frac{u\partial u}{\partial x} + \frac{v\partial u}{\partial y} + \frac{w\partial u}{\partial z} \\
 &= 2y^2(0) + 3x(4y) + 0 \\
 &= 12xy \\
 a_y &= \frac{u\partial v}{\partial x} + \frac{v\partial v}{\partial y} + \frac{w\partial v}{\partial z} \\
 &= 2y^2(3) + 3x(0) + 0 \\
 &= 6y^2
 \end{aligned}$$

$$\therefore a_{(1,2,0)} = (12 \times 1 \times 2)\hat{i} + (6 \times 2^2)\hat{j}$$

$$\Rightarrow a = 24\hat{i} + 24\hat{j}$$

22. (c)

23. (d)

For a laminar boundary layer

$$\frac{\delta}{x} = \frac{5}{\sqrt{R_{ex}}}$$

$$\Rightarrow \frac{\delta}{x} = \frac{5}{\sqrt{\frac{\rho v x}{\mu}}}$$

$$\therefore \delta \propto \sqrt{x}$$

$$\therefore \frac{\delta_2}{\delta_1} = \sqrt{\frac{2x_1}{x_1}} \Rightarrow \delta_2 = \sqrt{2} \delta_1$$

24. (b)

Buoyancy force acts through center of gravity of displaced liquid.

A large metacentric height in a vessel improves stability and makes time period of oscillation shorter.

25. (b)

Statement (3) corresponds to geometric similarity.

26. (a)

$$P = \frac{1}{2} C_D \rho U_\infty^3 A$$

$$P' = \frac{1}{2} (0.75 C_D) \cdot \rho U_\infty'^3 A$$

$$\therefore U_\infty'^3 = \left(\frac{100}{75} \right) \cdot U_\infty^3$$

$$\Rightarrow U_\infty' = 1.10 U_\infty$$

So, increase in speed = 10%

27. (c)

Bernoulli's assumed flow to be incompressible.

28. (a)

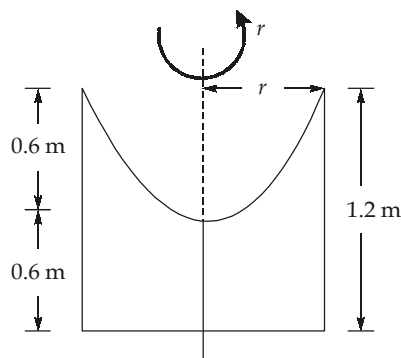

$$\begin{aligned} \text{Original volume of cylinder, } V_1 &= \pi r^2 h \\ &= \pi r^2 \times 1.2 \end{aligned}$$

Volume of liquid spilled out,

$$V_2 = \frac{1}{2} \pi r^2 h = \frac{1}{2} \pi r^2 \times 0.6$$

$$\therefore \frac{V_2}{V_1} = \frac{\frac{1}{2} \times 0.6 \pi r^2}{\pi r^2 \times 1.2} = \frac{1}{4}$$

29. (d)

Since angular momentum is conserved

$$m_1 V_1 r_1 = m_2 V_2 r_2$$

$$V_1 r_1 = V_2 r_2$$

$$50 \times 40 = V_2 \times 80$$

$$V_2 = 25 \text{ m/s}$$

30. (c)

Stability of floating body can be improved by making width large which will increase I and will thus increase the metacentric height and keeping the centre of mass low and making the draft small.

