

POSTAL Book Package

2023

Electrical Engineering Conventional Practice Sets

Microprocessors

Contents

Sl. Topic	Page No.
1. Introduction to 8085 and its Functional Organisation	2 - 9
2. Instruction Set of Microprocessor 8085	10 - 16
3. Programming of Microprocessor	17 - 22
4. Peripheral Devices and their Interfacing	23 - 30
5. Introduction to 8086 Microprocessor	31 - 38
6. Microcontrollers and Embedded Systems	39 - 42



MADE EASY
Publications

Note: This book contains copyright subject matter to MADE EASY Publications, New Delhi. No part of this book may be reproduced, stored in a retrieval system or transmitted in any form or by any means. Violators are liable to be legally prosecuted.

1

CHAPTER

Introduction to 8085 and its Functional Organisation

Q1 Explain what do you understand by microprocessor. List a few of its uses.

Solution:

Microprocessor is a programmable, clocked register based electronic device that reads binary instruction from its memory and does the processing over it.

Microprocessor is an electronic chip that has a computing and decision making capability. When this microprocessor is used as a CPU in a system, then it is called as a microcomputer.

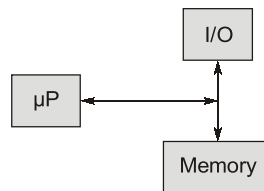

Uses of microprocessor:

- (i) Industrial PID controllers
- (ii) Calculators
- (iii) Data acquisition systems
- (iv) Laptop and personal computers

Q2 List the registers used in 8085.

Solution:

Registers are used in the microprocessor to store data temporarily during execution of program and may or may not be accessible to the users.

Important registers used in 8085 are:

- (i) Accumulator (8-bit)
- (ii) Register B (8-bit)
- (iii) Register C (8-bit)
- (iv) Register D (8-bit)
- (v) Register E (8-bit)
- (vi) Register H (8-bit)
- (vii) Register L (8-bit)
- (viii) Stack pointer (16-bit)
- (ix) Program counter (16-bit)
- (x) Flag register (8-bit)

Q3 Describe the flags of 8085 microprocessor.

Solution:

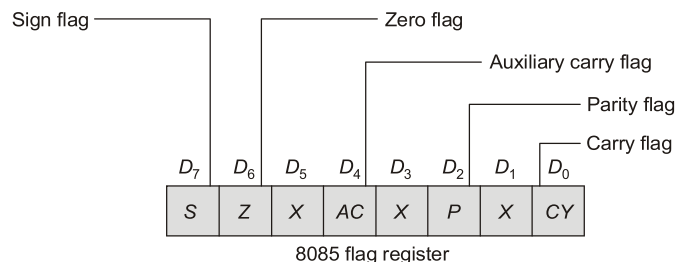

The 8085 microprocessor has 5 flags:

1. **Zero:** It is set to 1 when result is zero. Otherwise it is reset to zero.
2. **Carry:** If an arithmetic operation results in carry, it is set otherwise it is reset.
3. **Auxiliary carry:** In an arithmetic operation, when carry is generated by digit D_3 and passed to digit D_4 , the AC flag is set.
4. **Parity:** If the result has an even number of 1's the flag is set, for an odd number of 1's the flag is reset.
5. **Sign:** It is set if MSB of the result is 1, otherwise it is reset.

Q4 In 8085 microprocessor, what is the advantage of multiplexing the address bus with a data bus?

Solution:

Advantages of multiplexing the address bus with data bus are as follows:

1. Reduction in the number of pins required in the microprocessor. We save 8 pins at the cost of 1 ALE pin by using multiplexing.
2. Reduction in cost of microprocessor.
3. Reduction in space required by the microprocessor.
4. More efficient use of address bus since if it was used only for addressing, it would have remained idle for most of the T states.
5. Multiplexing address and data buses in the microprocessor allows for multiplexing in other peripheral devices as well without additional hardware. This results in a lot of cost + space saving for the whole circuit.

Q5 Describe the various addressing modes in the microprocessor 8085. Give suitable examples for each addressing mode.

Solution:

1. **Immediate addressing mode:** In this mode, the 8/16 bit data is specified in the instruction itself as one of its operand. Eg. MVI B, 20 H
2. **Register addressing mode:** In this mode, the data is copied from one register to another i.e. the operands are specified as contents of a register. Eg. MOV A, B
3. **Direct addressing mode:** The address of the operand is specified in the instruction.
Eg. LDA 3000 H
4. **Indirect addressing mode:** The data is transferred from the address pointed by the data in a register to another register. The address of the operand is in a register. Eg. MOV A, M
5. **Implied addressing mode:** The operand is implicit in the instruction and is not given explicitly.
Eg. RAL, CMP etc.

Q6 Explain different types of interrupts available in an 8085 microprocessor in details.

Solution:

An interrupt is a signal to the processor generated by hardware or software indicating an event that needs immediate action.

Types of Interrupts:

The 8085 has multilevel interrupt system. It supports two types of interrupts:

- (a) Hardware (b) Software

Hardware: An external device initiates the hardware interrupts and placing an appropriate signal at the interrupt pin of the processor. If the interrupt is accepted, then the processor executes an interrupt service routine.

Software: The cause of the interrupt is an execution of the instruction. These are special instructions supported by the microprocessor. After execution of these instructions microprocessor completes the execution of the instruction it is currently executing and transfers the program control to sub-routine.

There are five hardware interrupts:

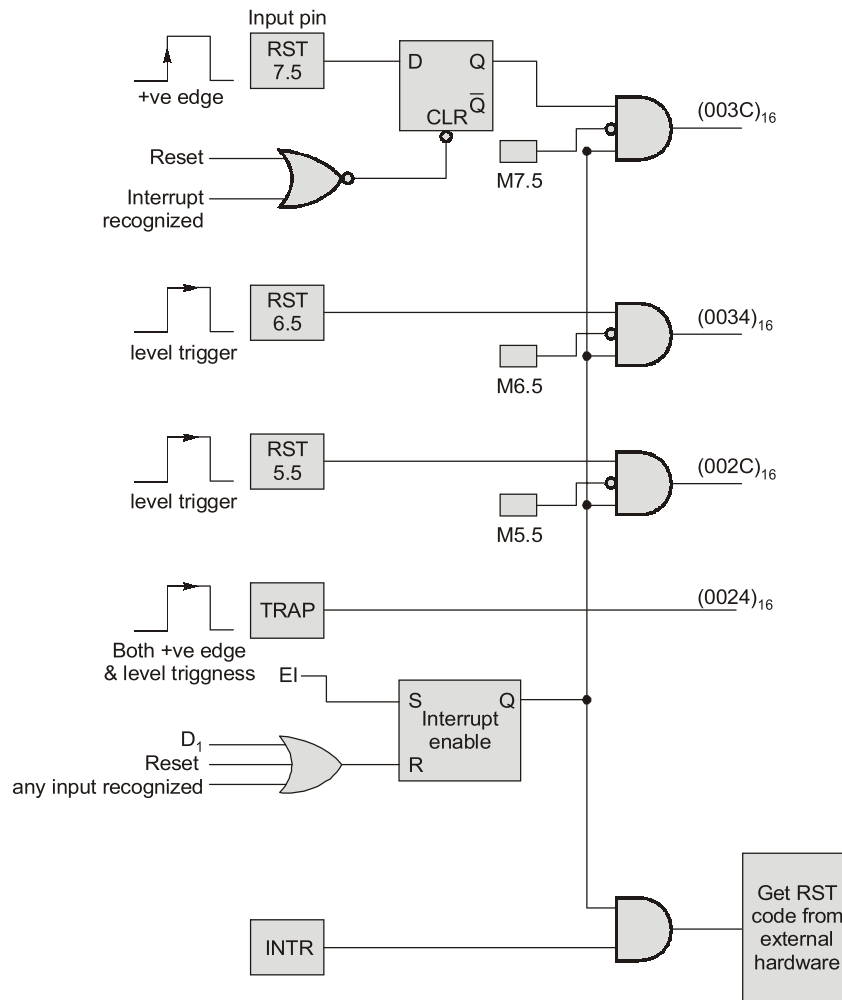

TRAP:

- is a non-maskable interrupt.
- TRAP has the highest priority and vectored interrupt
- +ve edge and level triggered
- in case of sudden power failure, it executes a ISR and send the data from main memory to back up memory.

RST 7.5:

- is a maskable interrupt
- has the second highest priority
- is edge sensitive
- enabled by EI instruction

RST 6.5 & 5.5:

- both are level triggered i.e. input goes to high and stay high until it recognized
- maskable interrupt
- RST 6.5 has 3rd priority and RST 5.5 has 4th priority